

CORROSION PROTECTION FOR FLAT-ROLLED STEEL PRODUCTION

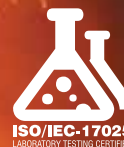

"Wrapper Queen"
As featured in the
"Packaging World®"
Magazine.



CORTEC
CORPORATION

Environmentally Safe VpCl®/MCl® Technologies

PICKLING OF THE HOT ROLLED COILS AND DISPOSITION OF COILS FROM THE PICKLE LINE

As the strip exits the acid tanks, it is rinsed with water to wash off any remaining acid. Frequently, however, traces of chloride or sulfate ions are left on the strip surface, often causing "speck" or pinpoint rust later in the processing. To reduce the incidences of "speck" rust, the use of **Cortec® VpCI-609® Powder** in the pickle line rinse water is recommended.

After exiting the pickle line rinse tanks, the strip is then wound into coils destined for either the cold finishing mill (tandem mill), or shipped as hot rolled

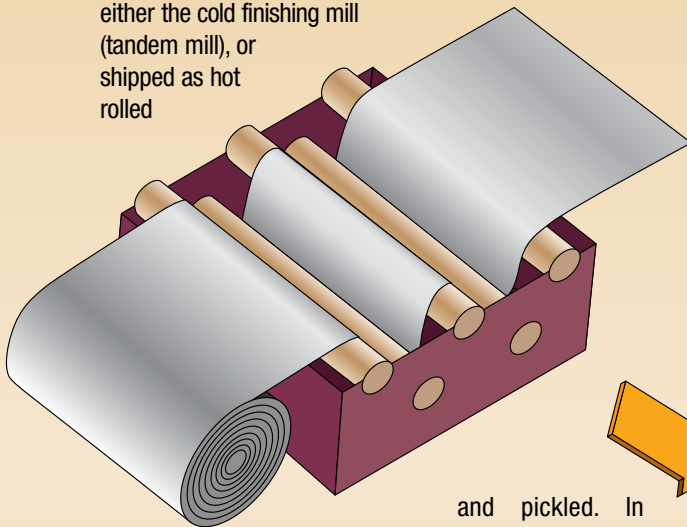

and pickled. In either case, a surface and/or edge treatment of the coil with oil or water based **VpCI®** products is recommended.

These coils may be edge sealed or "cocooned" with a ready-to-use **VpCI®-369D** or **VpCI®-389D** (water-based version). For those coils going to further cold finishing operations, two choices are available. For those wanting an oil free steel, **Cortec® VpCI®-347** or **VpCI®-377** diluted with water are recommended as a full surface treatment. For those wishing oiled steel, use a full surface treatment of **VpCI®-325** rust preventative oil.

COLD REDUCTION OF HOT ROLLED PICKLED STRIP-TANDEM MILL ROLLING

After being hot rolled and pickled, the steel strip is still too thick and too "soft" for use. Cold reduction takes place in the tandem mill.

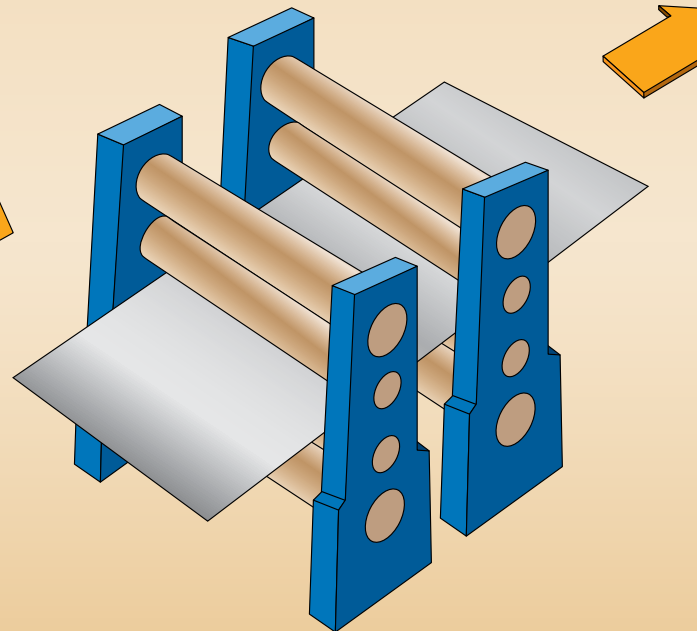

ANNEALING

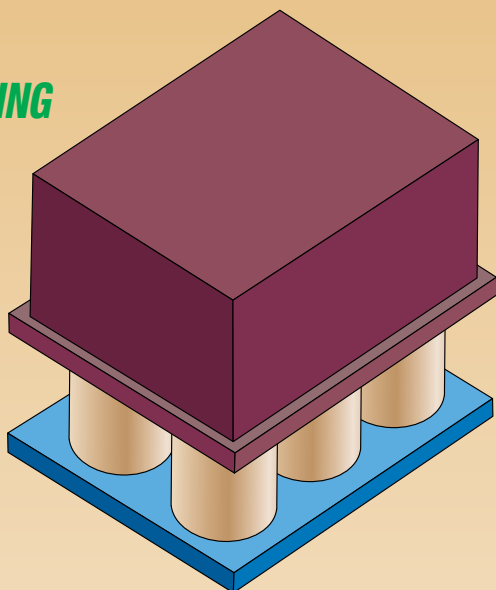

VpCI® FLUIDS PROTECT IN-PROCESS

Galvanizing, aluminizing, tinning, black plate, and coil paint also need protection after processing. Cortec's proven oil or water based protection for surface and edge treatments are fully compatible to assure **Total Corrosion Control.**

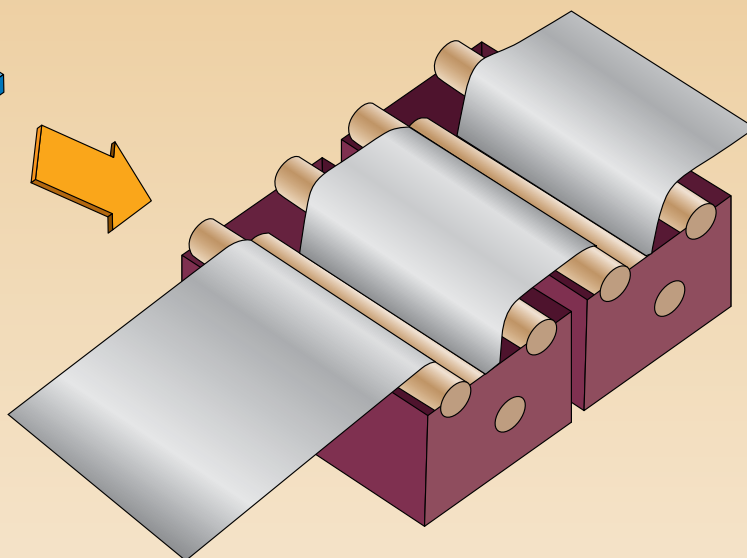

FINISHING OPERATIONS

Following cold reduction and annealing, the steel is subject to corrosion prior to further finishing operations. Edge treatment with **Cortec® VpCI®-337** will protect coils in-process for subsequent operations.

TEMPER ROLLING

To provide the cleanest strip possible, most material is wet rolled at the temper mill. For cold rolled steel, **Cortec® VpCI®-344** diluted with water can be used as a wet tempering fluid.

For galvanized or aluminized steels, **Cortec® VpCI®-347** diluted with water at a range of 2.5%-5% is recommended as a wet tempering fluid.

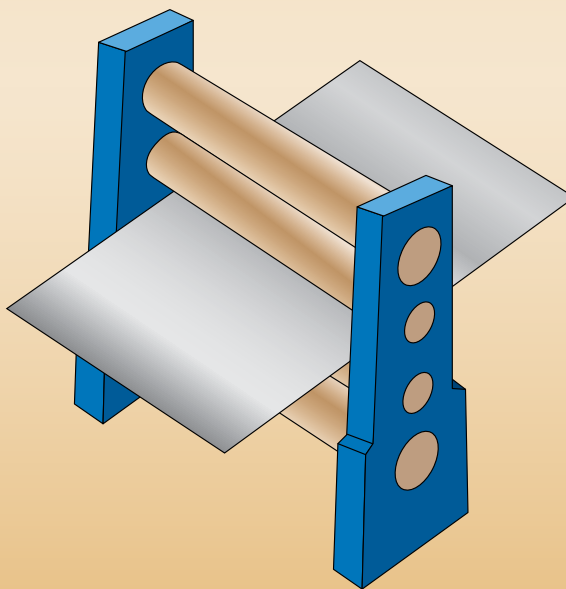

ENVIRONMENTALLY FRIENDLY ISO 14001 CERTIFIED

“If controlling and delivering corrosion free steel were simply choosing the right packaging materials, your work in the steel industry would be much less complex. Cortec Corporation since 1977 has been committed to solving all corrosion problems. By exploring innovative technology at Cortec Laboratories, we are fulfilling that vision every day with Total Corrosion Control .”

– Boris A. Miksic, President & CEO

STOP CORROSION NOT PRODUCTION!

Cortec's Total Corrosion Control keeps you running from start to finish. Producing quality flat rolled steel doesn't happen without all systems operating properly and consistently- don't let them fail by corrosion. Cortec® MCI®/VpCI® technologies protect concrete foundations, tanks, valves, motors, compressors, circuit boards, electrical boxes, bearings and everything you depend on to keep production rolling.



CORTEC® VpCI® PACKAGING PRESERVES QUALITY!

Cortec® packaging technology preserves manufactured products like a tin can preserves tomatoes. Complete multimetal corrosion protection integrated in a wide variety of packaging products assures delivery of corrosion-free metal worthy of your reputation. Designed for specific applications and systems, these cost effective Cortec® packaging products also minimize handling damage, lower labor costs, reduce overall packaging costs and assure environmentally friendly results.

CORTEC® VpCI® PROTECTS!



Traditional rust preventatives do not stop speckling on the internal coil surfaces but VpCI® protects. Humidity and condensed moisture easily penetrate the coil forming a highly corrosive environment inside the coil. Rust, speckling and staining can develop in minutes under these conditions. VpCI® Vapor phase Corrosion Inhibiting action emits wherever humidity and corrosive agents can penetrate to provide complete corrosion protection.

CORTEC® VpCIs CUT COSTS!

- Water-based VpCIs are more economical than conventional oil-based rust preventatives.
- Efficient application results in labor savings.
- Eliminates use of messy and toxic coatings.
- Minimizes packaging materials and costs.

VpCI® treatments virtually eliminate economic loss due to rust, speckling, staining, and other forms of corrosion. You can eliminate claims and returns while improving the quality of your product. As a result, your processing will become more streamlined leading to more efficient operations overall.

	Annual Economic Loss Due to Corrosion	Cost of VpCI® Treatment to Protect Total Production	Total Savings With Cortec® VpCI®
Per Shift	\$4,500	\$100	\$4,400
Per Day	\$13,500	\$300	\$13,200
Per Week	\$94,500	\$2,100	\$92,400
Per Month	\$410,625	\$9,125	\$401,500
Per Year	\$4,927,500	\$109,500	\$4,818 000

Figures are based on a steel mill producing and shipping 100 ten ton coils per shift, three shifts per day, seven days per week, a nominal material and manufacturing cost of \$300 per ton, with a 1.5% economic loss due to corrosive attack.

ENVIRONMENTALLY FRIENDLY ISO 14001 CERTIFIED

INNOVATIVE CORTEC® CORROSION PROTECTION SOLUTIONS

Flat-rolled steel packaging remained virtually unchanged for 25 years until Cortec Corporation pioneered the development of Vapor phase Corrosion Inhibitor plastic films in 1982. This VpCI® technology complimented Cortec's proven metal working fluids and other packaging products which ultimately led to Cortec's Total Corrosion Control methodology protecting metal from ingot to finished product. Cortec® packaging materials and systems assure delivery of flat-rolled steel product at its destination in prime condition.

FOR IN-PLANT TRANSIT AND STORAGE



Cortec® film products incorporate a patented VpCI® Vapor phase Corrosion Inhibiting technology which has become the most noteworthy advancement in metals packaging since reinforced steel wrap was first introduced in 1968. By infusing VpCI® chemistry as an integral part of the film, protective vapors are emitted which form a thin, mono-molecular and extremely effective protective barrier on the steel. This protective layer is self-replenishing providing continuous protection even in the presence of moisture vapor or condensation. No special cleaning is required prior to painting, plating, stamping, welding, forming etc.

PACKAGING SOLUTIONS



Cortec® VpCI® papers, paperboard, and flexible packaging substrates eliminate the need for a variety of materials to protect your metals. The cleanest neutral natural kraft prevents contamination and is simple to use. These fibre products are environmentally safe, fully recyclable, repulpable, bio-degradable, and non-toxic. They provide exceptional protection for dry or oiled metals during storage, transit, and export shipments.

TOTAL CORROSION CONTROL® • TOTAL CORROSION CONTROL®

CORTEC® LEADS THE WAY PACKAGING PRIMARY COILS.

Whether “thru the eye”, cocooned, or on skids, Cortec® has been the leader paving the road to more efficient corrosion-free flat-rolled steel packaging.

BHP STEEL, AUSTRALIA

– SINCE 1991

Feasibility of the “thru-the-eye” stretch system made possible by **Cor-Pak® VpCl® Stretch Film**. This method originated in Australia and now coil wrapping stretch machines are common practice around the world running **Cor-Pak® VpCl® Stretch Film**.



WEIRTON TIN MILL, USA

– SINCE 1993

Cortec® films reduced costs significantly by mechanizing wrapping system, which eliminated steel strapping, reduced labor costs, while preventing corrosion in transit.



THOMAS STRIP MILL, USA

– SINCE 1999

Utilizing the proven VpCl® stretch method to wrap stacks, Cortec® packaging products made possible an innovative change lowering labor costs and minimizing use of packaging materials.

ENVIRONMENTALLY FRIENDLY ISO 14001 CERTIFIED

TIRED OF - Rust Claims, High Packaging Costs, Environmental Concerns

THEN - Break with the Past, Switch to Cortec® VpCI®, Innovative Solutions

BUYER'S GUIDE - VpCI® CLEANING AND SURFACE PROTECTION SYSTEMS

PRODUCT	DESCRIPTION	PACKAGING	APPLICATIONS
VpCI®-325	Ready-to-use thin - film oil based liquid for multi-metal corrosion protection. Provides excellent protection to high surface finishes, ie. minimum spangle galvanized steels.	5 gal. (19 l), 55 gal (208 l) totes, bulk	Ready to use RP oil for full surface applications to replace conventional slushing oils.
VpCI®-422	Environmentally friendly, biodegradable rust and stain remover for ferrous and non-ferrous metals. Incorporates VpCI® technology so that it is not aggressive to the metal substrate. Will not harm human skin, most paints, plastics, rubber, or other materials.	5 gal. (19 l), 55 gal (208 l) totes, bulk	Derusting of coils, sheets and machinery by dipping, brushing and spraying. Replaces inorganic acids ie: phosphoric, sulfuric, etc.
VpCI®-337	Water-based concentrate that is excellent for fogging of internal spaces of railcars, barges and containers. Also provides excellent protection when used as an edge spray for shipping and storage applications. Contains vapor phase corrosion inhibitors for multi-metal protection.	5 gal. (19 l), 55 gal (208 l) 13 oz. (369 gram) fogger	Edge protection of dry steel coils, stacks, etc. Excellent on electrical, galvanized, aluminized and cold rolled steels.
VpCI®-338	Water-borne corrosion inhibitor that is excellent for edge-treating of coils and sheet metal stacks and for fogging of trailers. Particularly effective on ferrous metals, aluminum, and tin-plate. FDA approved for indirect contact with food.	5 gal. (19 l), 55 gal (208 l)	Edge treatment of aluminum, tin and black plated coils and stacks for use in food packaging containers (cans).
VpCI®-344	Water-borne corrosion preventative coolant for use in wet tempering of galvanized or cold-rolled steel. Also can be used in light stamping operations where some lubrication is required.	55 gal (208 l) totes, bulk	Wet tempering of cold rolled, and galvanized steel. Diluted with water 1:10 as a wet tempering fluid.
VpCI®-347	Water based dry lubricant/corrosion inhibitor. Effective in dilutions as low as 1:40 in water.	5 gal. (19 l), 55 gal (208 l) totes, bulk	Full surface treatment to replace chromate conversion coating on galvanized steel.
VpCI®-369 VpCI®-369D	Oil-based barrier coating that provides extended, outdoor, multimetal protection. Leaves a translucent, oily film that is scratch resistant and self-healing. Product can be diluted with oil. Can be easily removed with common cleaners. Meets MIL-C-16173D Grade 2 (QPL product). VpCI®-369D is prediluted version of VpCI®-369.	5 gal. (19 l), 55 gal (208 l) 12 oz. (.35 l)	Edge treatment of oiled coils and stacks. For export shipment and outdoor storage of hot rolled, CR, galvanized and aluminized steels.
VpCI®-377	Water-soluble, biodegradable, rust preventative concentrate designed as a direct replacement for oil-based rust preventatives. Leaves a transparent, dry film and can be used at low concentrations.	5 gal. (19 l), 55 gal (208 l) totes, bulk	Corrosion preventive for transit protection of cold rolled, hot rolled and galvanized steels.
VpCI®-389	Water-borne temporary coating for outdoor storage protection. Leaves a translucent, waxy coating that is easily removable. Low in VOC's and dilutable with water.	5 gal. (19 l), 55 gal (208 l) totes, bulk	Edge treatment of prepainted coils.
VpCI®-418/ VpCI®-418L	Heavy-duty alkaline cleaner and degreaser. Non-foaming cleaner that provides multi-metal corrosion protection after the cleaning process.	50 lb (23 kg) boxes, and 100 lb (45.4 kg) drums 5 gal. (19 l), 55 gal (208 l) drums, liquid totes and bulk. Safe-T-Charges 5 lb (2.3 kg) water soluble bags	Cleaning and degreasing of hot rolled, cold rolled and galvanized steels.

BUYER'S GUIDE - ENVIRONMENTALLY FRIENDLY MRO PRODUCTS FOR EQUIPMENT AND INFRASTRUCTURE CORROSION PROTECTION

PRODUCT	DESCRIPTION	PACKAGING	APPLICATIONS
VpCI®-111	Tyvek® breathable membrane, plastic cartridge filled with nitrite free VpCI®, for multimetal protection. Comes with adhesive backing and is individually packaged in plastic.	10/carton	Corrosion protection of electrical and electronic equipment in the steel mills.
VpCI®-329	Oil-based concentrate for use in gearboxes, crankcases and other lubrication systems. Provides excellent corrosion protection in both the liquid, and vapor phases. Also available in ready-to-use (VpCI®-329D), and FDA approved (VpCI®-329F) versions. Meets MIL-46002 and MIL-I-85062 (AS) stain.	5 gal. (19 l), 55 gal (208 l) totes, bulk.	Additive for lube, hydraulic and rust preventive oils.
VpCI®-423	Environmentally friendly rust and tarnish remover gel that is excellent for application to vertical surfaces and hard to reach areas.	5 gal. (19 l), 55 gal (208 l) 16 oz (0.47 l), 16 oz (397 gram) sprays.	Derusting of coils, sheets and machinery by dipping, brushing and spraying.
VpCI®-617	Water soluble, provides long-term protection against corrosion and scale formation. Suitable for low to medium pressure boilers.	5 gal. (19 l), 55 gal (208 l) drums.	Boiler water and steam anti-corrosion and anti-scaling treatment.
VpCI®-646	Water soluble treatment protects cooling and industrial process water systems against corrosion, scale and fouling. Environmentally safe.	5 gal. (19 l), 55 gal (208 l) drums.	Cooling water anti-corrosion and anti-scaling treatment.
VpCI® CorrVerter®	Water-based corrosion converting primer for application to rusted surfaces. Contains a chemical chelating agent that converts the rust to a paintable surface.	16 oz. (0.45 l) jars, 5 gal. (19 l), 55 gal (208 l) drums	Rust converter for corroded structured steel, equipment, tanks, rail cars, locomotives, ships, etc.
MCI® HPRS	Complete corrosion protection system for repair of spalled and cracked concrete utilizing Cortec's MCI® (Migrating Corrosion Inhibiting technology).	8.3 lb. (3.75kg) pails - resin 55.1 lb. (25kg) bag - powder	Repair, rehabilitation and restoration systems for reinforced concrete and masonry structures in steel mills.

TOTAL CORROSION CONTROL • TOTAL CORROSION CONTROL

BUYER'S GUIDE – VpCI® PACKAGING PRODUCTS

PRODUCT	APPLICATION	DESCRIPTION
Cor-Pak® EX VpCI® Film (HDPE)	Used for interleaving cut sheets, slit coils, and other palletized applications.	High density polyethylene film extruded with VpCI®. Protects ferrous and non-ferrous metal. Excellent barrier. 1.25 mil (25-30 microns).
VpCI-126®	Customizable PE used as bags, sheeting, and tubing for specific needs.	Unique dual action: desiccant/VpCI® protection. Transparent plastic films with VpCI® for multimetal protection. Heat sealable. Also available in Zip-Lock® bags, and Shrink film varieties. Conforms to MIL-PRF-22019D and MIL-B-22020D. FDA approved and recyclable.
EcoWeave®	Excellent for coil wrapping and pallet wrapping.	Transparent VpCI® film designed for use in applications where additional strength and tear resistance are required. FDA approved and recyclable.
Eco-Corr Film®	Customizable biodegradable film used as bags, sheeting, and tubing for specific needs.	Fully biodegradable (per ASTM D 5338), aliphatic polyester film, utilizing Cortec's patented VpCI® technology.
CorShield® Fabric	Excellent for coil wrapping and pallet wrapping.	CorShield®, patented, is a multiple-layered protective fabric with a non-woven, soft inside layer. CorShield® is made from low-density polyethylene tapes, a high-density coating and is extrusion laminated.
VpCI®-146 Paper	Standard craft paper used for interleaving, top and bottom sheets, and parts wrapping.	VpCI® kraft paper protects ferrous and non-ferrous metals. Nitrite and chromate free. Fully recyclable. Conforms to MIL-PRF-3420G.
Cor-Pak® Stretch Film	Stretch wrap used for coil wrapping, slit coil wrapping, sheets, etc.	NEW unique dual action: desiccant/VpCI® protection. Holds protected parts securely in place, transparent. Does not leave residue on parts. Multimetal protection. Available in machine and handwrap grades. FDA approved and recyclable.
Cor-Pak® Stretch Anti-Stat	Anti-Stat Stretch wrap used for coil wrapping, slit coil wrapping, sheets, etc.	Anti-stat dual action: desiccant/VpCI® protection. Holds protected parts securely in place, transparent. Does not leave residue on parts. Multimetal protection. Available in machine and handwrap grades. Recyclable.
Cor-Pak® Linerboard	Pretreated linerboard that is used as the inner liner of corrugated products.	VpCI® treated linerboard that is recyclable and repulpable and eliminates the need for a secondary packaging source.
Cor-Pak® VpCI® Corrugated PE Sheeting	Replacement for corrugated cardboard, or non-VCI PE corrugated.	FDA approved, 100% recyclable packaging material. Easily fabricated into boxes, containers and custom totes.
VpCI®-350/VpCI®-350AB	Coating for edge protectors, coil inserts, and corrugated sheeting.	Coating for the paper, folding box and corrugated box industry. Produces a thin, non-penetrating coating for paper, chip-board and cardboard.

Visit our website for more information on Cortec® Vapor phase Corrosion Inhibitors.

CortecVCI.com

TOTAL CORROSION CONTROL

Cortec® Corporation is dedicated to controlling corrosion at all stages of a product life cycle. Cortec® Corporation has developed a diverse range of corrosion protection products including cleaners, metalworking fluids, water and oil-based coatings and corrosion inhibitors, rust removers, paint strippers, emitters, powders, packaging foams, paper, films, surface treatments and admixtures for concrete as well as additives for water, oil & polymers. Contact Cortec® for additional brochures and information.

LIMITED WARRANTY

All statements, technical information and recommendations contained herein are based on tests Cortec® Corporation believes to be reliable, but the accuracy or completeness thereof is not guaranteed.

Cortec® Corporation warrants Cortec® products will be free from defects when shipped to customer. Cortec® Corporation's obligation under this warranty shall be limited to replacement of product that proves to be defective. To obtain replacement product under this warranty, the customer must notify Cortec® Corporation of the claimed defect within six months after shipment of product to customer. All freight charges for replacement product shall be paid by customer.

Cortec® Corporation shall have no liability for any injury, loss or damage arising out of the use of or the inability to use the products.

BEFORE USING, USER SHALL DETERMINE THE SUITABILITY OF THE PRODUCT FOR ITS INTENDED USE, AND USER ASSUMES ALL RISK AND LIABILITY WHATSOEVER IN CONNECTION THERE WITH. No representation or recommendation not contained herein shall have any force or effect unless in a written document signed by an officer of Cortec® Corporation.

THE FOREGOING WARRANTY IS EXCLUSIVE AND IN LIEU OF ALL OTHER WARRANTIES, EXPRESS, IMPLIED OR STATUTORY, INCLUDING WITHOUT LIMITATION ANY IMPLIED WARRANTY OF MERCHANTABILITY OR OF FITNESS FOR A PARTICULAR PURPOSE. IN NO CASE SHALL CORTEC® CORPORATION BE LIABLE FOR INCIDENTAL OR CONSEQUENTIAL DAMAGES.

Distributed by:



4119 White Bear Parkway, St. Paul, MN 55110 USA
 Phone (651) 429-1100, Fax (651) 429-1122
 Toll Free (800) 4-CORTEC, E-mail: info@cortecvci.com
 www.CortecVCI.com

printed on recycled paper 100% post consumer

Revised: 09/10 Supersedes: 03/09.
 Cortec®, BioCorr®, BioCortec®, BioCushion™, Boiler Lizard®, Closed Loop Toad®, Cooling Tower Frog®, VpCI®, VpCI® Film Color of Blue®, VpCI-126®, VpCI-609®, VpCI-137®, VmCI-307®, EcoWorks®, EcoAirs®, Eco-Corr®, EcoLine®, EcoClean®, EcoShield®, EcoWeave®, EcoSpray®, EcoCoat®, EcoEmitter™, EcoSol™, Eco-Tie™, Eco-Card™, Eco-Shrink™, EcoWrap®, Eco Films®, Cor-Mitt®, Cor-Pak®, CorShield®, CorSol®, Corrosorbbers®, CorWipes®, CorVerter®, Corr Seal®, Corrlam®, Cor-Fill™, Corrlube™, CRI®, Desiccant®, ElectriCorr®, GalvaCorr®, Super Corr®, HPRS®, CRI®, MCI®, MCI Grenade®, Milcorr®, Nano VpCI™, and Rust Hunter™ are trademarks of Cortec® Corporation.
 ©Cortec Corporation 2010. All rights reserved